



DMC400A8G 4 Core network controller and server

Introducing the new DMC400 series of all-in-one controllers and network management engines. The DMC400 series devices seamlessly integrate with the DMT IO module family and other 3<sup>rd</sup> party devices and systems. The DMC series controllers enable unparalleled compatibility to enhance your control infrastructure. Powered by Niagara Framework, the DMC400 series device range empowers your network with advanced integration and control capabilities.

## Features

The DMC400A8G is an all-in-one controller and network management engine with the following features:

- One modular PJ Panel Bus port (right side of controller) for ultra high-speed, in-panel connection to the DMT family IO modules. The PJ Panel bus network supports up to 128 IO points. Available physical single row space for devices should be considered when using modular PJ Bus connections. <sup>Note 1.</sup>
- One PJ Field Bus port for high-speed connection to DMT series IO modules located in remote panels. The PJ Field bus port supports up to 320 IO points. <sup>Note 1.</sup>
- Two RS-485 serial communication ports that allow for integration with third party devices such as energy meters, variable speed drives and 3<sup>rd</sup> party BACnet MSTP or Modbus RS485 field controllers. Each RS485 port supports up to 31 devices. <sup>Note 1.</sup>
- Two 10/100/1000mb ethernet ports allow for direct networking capabilities for IP devices.
- BACnet IP and Modbus TCP supported via Ethernet ports.
- Support for Niagara Fox and Fox(s) protocol
- Support for Open Building Information Exchange (oBIX) and Web Services
- Enabled for future support of other serial protocols within Niagara Framework
- On board port for support of future touch screen (DMC 410 Series controllers).
- One modular communications options port (left side of controller) to support future wireless communications accessories.
- DMC 400 series controllers are fully compatible with the Niagara Framework version 4.xx and above.
- Historical data, alarms, and schedules are supported along with a full library of control objects that can be created, configured, and edited through standard Niagara Workbench functionality.
- Internet connectivity and Web serving capabilities enable the DMC400 series network controller family to host and serve Niagara based graphics displays to a standard web browser via an Ethernet LAN.

**NOTE 1:** For actual maximum point and device capacities please consult the DMC series Architectural Guidelines document (document reference number here) for further information. Ensure controller is licensed to suit design point capacity.

### Architecture and Communications

The DMC400 series controller family enables high speed serial communications at up to 500kbps for the PJ Field bus and the PJ Panel bus connections.

The DMC400 series controller supports PJ Panel bus connections at 500kbps through the modular panel bus connection on the left side of the controller. PJ Panel Bus allows for the connection of up to 128 points maximum per PJ Panel Bus network. PJ Panel Bus power supply from the DMC series controller supports up to 64 points via DMT series IO modules internally. If more than 64 points are required an extra 24 Volt power supply needs to be added.

The DMC400 series controller family also enables PJ Field bus connection at up to 500kbps via the removable grey PJ-Bus terminal block on the bottom right side of the controller. PJ Bus DMT IO module devices may be located remotely up to 1000m/3280ft from the parent DMC400 series controller. A maximum 320 points can be connected to a single PJ Field bus network.

PJ-Field bus length should determine the PJ Field bus baud rate. PJ Field bus baud rate is determined by the DMT IO module address range. All DMT IO modules on the same PJ field bus network should be addressed in the same baud rate range. The DMC400 series controller automatically adapts the baud rate depending on the address range selected for DMT IO modules.

The DMC400 series controller also supports 2 x serial port connections each configurable as BACnet MSTP or Modbus RS485. The port speed and protocol are selected via Niagara Workbench.

The DMC400 series controller is furnished with 2 x Ethernet ports supporting BACnet IP, Modbus TCP, Fox, Fox(s) protocol and Web Server connections.

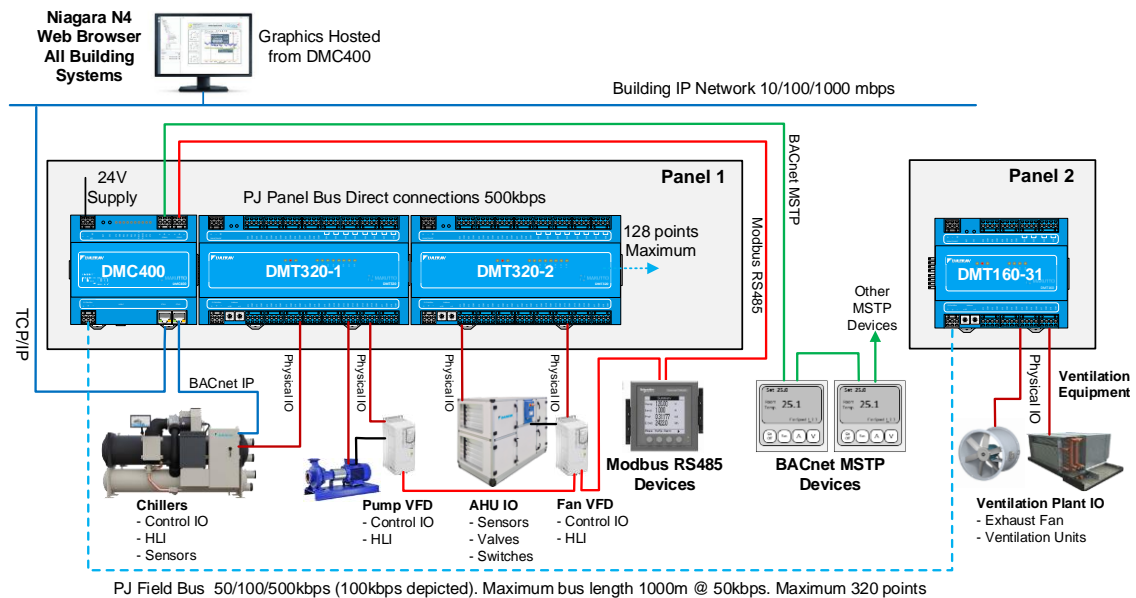

Application depicting DMC400 series controller with PJ Panel Bus, PJ Field Bus, Modbus, and BACnet MSTP/IP and Web Services connections.

### Technical Data

Item	Description	Details
Hardware	Power Supply	Class 2 Device 24VAC +20% / -15% 24VDC +/-3%
	Power Consumption	9.6VA AC/300mA DC. When supplying 4 x PU to PJ Panel Bus max consumption is 60VA AC or 700mA DC.
	Processor	Quad-core Cortex-A53 (ARMv8) 64-bit SoC @ 1.4GHz
	Memory -RAM	2GB DDR4 SDRAM
	Memory -Flash	8GB eMMC storage
	Ethernet communication ports	Ethernet Ports x 2 10/100/1000 Mbps (1GB connection not presently used)
	Serial communications ports	2 x RS-485 – Modbus RS485, BACnet MSTP. Isolated ports. Supports baud rates up to 115.2kbps
	PJ Panel Bus port for DMT Expansion Modules.	Maximum of 128 IO points per PJ Panel Bus network connection. Baud rate @500kbps
	PJ Field Bus port for DMT Expansion Modules.	Maximum of 320 IO points per PJ Field Bus network connection. Baud rate selectable between 50/100/500kbps
Software	Framework	Niagara N4 Framework, developed by Tridium Fox Protocol -Workbench/Web Browser - Common programming tool
	Protocols Supported	Niagara Protocol (Fox,Foxs), BACnet, Modbus, Web & oBIX
	Others	HTML5 web user interface running Niagara 4 Framework. Supports JAVA Web Start without JAVA Plug-Ins Supports e-mail service SMTP Protocol Support SNMP (Simple Network Management Protocol)
Compliance	North America	UL 60730 Energy Management Equipment** c-UL Canada** FCC 47 CFR Class B, Part 15, Sub-part B, ICES-003 Issue 7
	Europe	IEC 60730, EMC
	UK CA	IEC 60730, EMC
	Oceania RCM	IEC 60730, EMC AS/NZS CISPR 32:2015 AMD1:2020
	Others	RoHS2, REACH, WEE. BACnet Testing Laboratory**
Environmental	Operating Temperature	0 °C ~ 50 °C
	Storage Temperature	-20 °C ~ 65 °C
	Operating Humidity	10% ~ 90% RH, non-condensing
Mechanical	Dimension	138mm x 120mm x 50mm
	Weight	900 grams
	Material	Base: Plastic Cover: Plastic
	Mounting	35mm DIN rail mount options standard and keyhole slots
	IP Rating	IP20
	Cooling	Internal air convection

\*\* Compliance is in progress

### Ordering Information

Product Code	Description	Details
DMC400A8G-N4	Network Control Engine - Standard	Standard - Niagara 4 - 2GB RAM /8GB Flash

### Product dimensions

